



Model
OS

OS
Steel Oil Water Separators

The OS Series oil water separators are designed per the American Petroleum Institute (API) separator design guidelines.

Pan America Environmental OS Series, steel oil/water separators are a high performance, coalescing design for removal of free and finely dispersed oil droplets from oily wastestreams. The design follows the American Petroleum Institute's (API)#421 Design & Operation of Oil/Water Separators Manual, February 1990.

OS performance: <10mg/L, 30-micron free, dispersed and non-emulsified oil droplets.

The OS steel design is one of 8 different oil/water separator designs from Pan America Environmental that can be used singularly or in combination with other treatment processes such as emulsion cracking, DAF & clarifier pretreatment.

The OS separators have the benefit of being compact with a small footprint.

The separators are available in capacities from 5 to over 5000 GPM for installation above, flush with grade or below grade and can operate via gravity or pumped flow.

Our designs can be used to separate oils, fuels, fuel oils, bunker, refined petroleum derivatives, LNAL, DNAPL, vegetable oils, mineral oils and FOG and more.

Standard Features:

- ◆ A36 or 304 or 316 SS construction
- ◆ Adjustable water weir
- ◆ Integral oil reservoir
- ◆ Influent diffuser
- ◆ Effluent chamber
- ◆ Gasketed vapor cover
- ◆ NPT/flanged fittings
- ◆ Vent fittings
- ◆ V-hopper Bottom
- ◆ Flopak coalescing media
- ◆ Skid base/lifting lugs

Typical applications:

- ◆ Groundwater remediation
- ◆ Mobile separation system
- ◆ DAF/Clarifier pretreatment
- ◆ Power plant water treatment
- ◆ Refinery process water
- ◆ Aircraft wash racks
- ◆ Machining coolant oil removal
- ◆ Tank farm tank bottoms
- ◆ Vehicle washwater treatment
- ◆ R.O. Filter pre-treatment
- ◆ Oil spill recovery
- ◆ Trench water treatment
- ◆ Bilge water treatment
- ◆ Hydraulic fluid tank de-watering



Model
OS

OS

Steel Oil Water Separators

The OS separators can be provided with many options to create a complete, custom system design to fit your application and particular needs.

Customization of the separator tank is offered to further tailor the design to your needs.

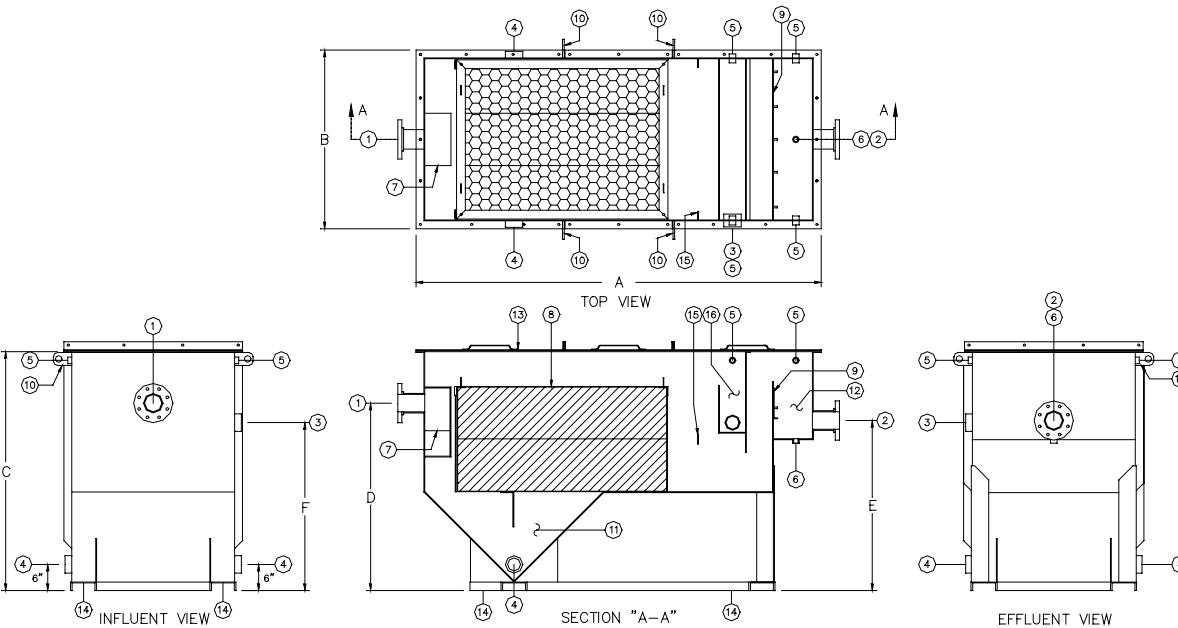

Options:

- Influent feed system
- Effluent pump out
- Oil pump out
- Sludge pumpout
- Retpak secondary coalescer
- Sight glass, oil/effluent
- Sludge auger
- Drum oil skimmer
- Pipe oil skimmer
- Belt oil skimmer
- Expanded effluent chamber
- Expanded oil reservoir
- Inlet preseparation/settling chamber
- Alternate media construction
- Effluent solids filter
- Effluent carbon (GAC) filter
- Effluent AQAM (organoclay) filter
- High level alarms
- Freeze protection
- Vent scrubber
- Oil monitor/readout system
- High temperature design
- 304 or 316SS tank construction
- Retpak secondary coalescing media
- Elevated design
- Walkways/platforms
- Trailer mounted systems
- Containerized systems
- External storage/pre-separation tanks
- pH neutralization system

Model	Length	Width	Height	Inlet	Outlet	Oil Outlet	Sludge Vol. Gal.	Oil Chamber Gal.	Inlet Size	Outlet Size	Sludge Outlet Size	Oil Outlet Size	Empty Weight	Operat. Weight	Flow Rate GPM (Max.)
	A	B	C	D	E	F									
OS-2	6'-0"	1'-6"	3'-0"	1'-11"	2'-0"	2'-1"	7	2	2"	2"	2"	2"	600	835	5
OS-4	6'-0"	2'-4"	3'-0"	1'-11"	2'-0"	2'-1"	15	4	2"	2"	2"	2"	654	1709	10
OS-8	6'-0"	2'-4"	4'-0"	3'-5"	2'-10"	3'-3"	15	4	2"	2"	2"	2"	800	2400	25
OS-12	6'-0"	3'-4"	4'-0"	3'-5"	2'-10"	3'-3"	30	6	3"	3"	3"	3"	1150	3500	36
OS-16	6'-0"	4'-4"	4'-0"	3'-5"	2'-10"	3'-3"	40	8	3"	3"	3"	3"	1300	4600	50
OS-24	7'-9"	3'-4"	4'-7"	3'-7"	3'-3"	3'-3"	66	12	4"	4"	3"	3"	1400	4745	72
OS-36	7'-9"	3'-4"	5'-7"	4'-6"	3'-9"	4'-3"	66	12	4"	4"	3"	3"	1520	5720	108
OS-48	7'-9"	3'-4"	6'-7"	5'-6"	4'-9"	5'-3"	66	15	4"	4"	3"	3"	1810	6902	144
OS-64	7'-9"	4'-4"	6'-7"	5'-6"	4'-9"	5'-3"	91	20	6"	6"	4"	4"	1920	9435	192
OS-80	7'-9"	5'-4"	6'-7"	5'-6"	4'-9"	5'-3"	113	25	6"	6"	4"	4"	2030	11404	240
OS-96	7'-9"	6'-4"	6'-7"	5'-6"	4'-9"	5'-3"	136	30	6"	6"	4"	4"	2142	13377	288
OS-128	7'-9"	8'-4"	6'-7"	5'-6"	4'-9"	5'-3"	158	40	6"	6"	4"	4"	2302	15396	384
OS-144	7'-9"	9'-4"	6'-7"	5'-6"	4'-9"	5'-3"	203	50	6"	6"	4"	4"	2802	19492	432

Item	Qty	Description	Item	Qty	Description	Item	Qty	Description	Item	Qty	Description	Item	Qty	Description
1	1	Inlet	4	1	Sludge outlet	7	1	Inlet Diffuser	10	4	Lift lug	13	3	Cover
2	1	Outlet	5	4	Vent 1" NPT	8	1	Flopak media	11	1	V-hopper	14	1	Skid
3	1	Oil Outlet	6	1	Drain 2" NPT	9	1	Weir	12	1	Effluent chamber	15	2	Retpak Lug
												16	1	Cover

Dimensions, design and capacities are not for construction and are subject to change without notice.

950 N. Rand Rd., Ste 120 Wauconda, IL 60084 USA 847-487-9166 fax: 847-487-9218 panam@panamenv.com



Model
OS

OS

Steel Oil Water Separators

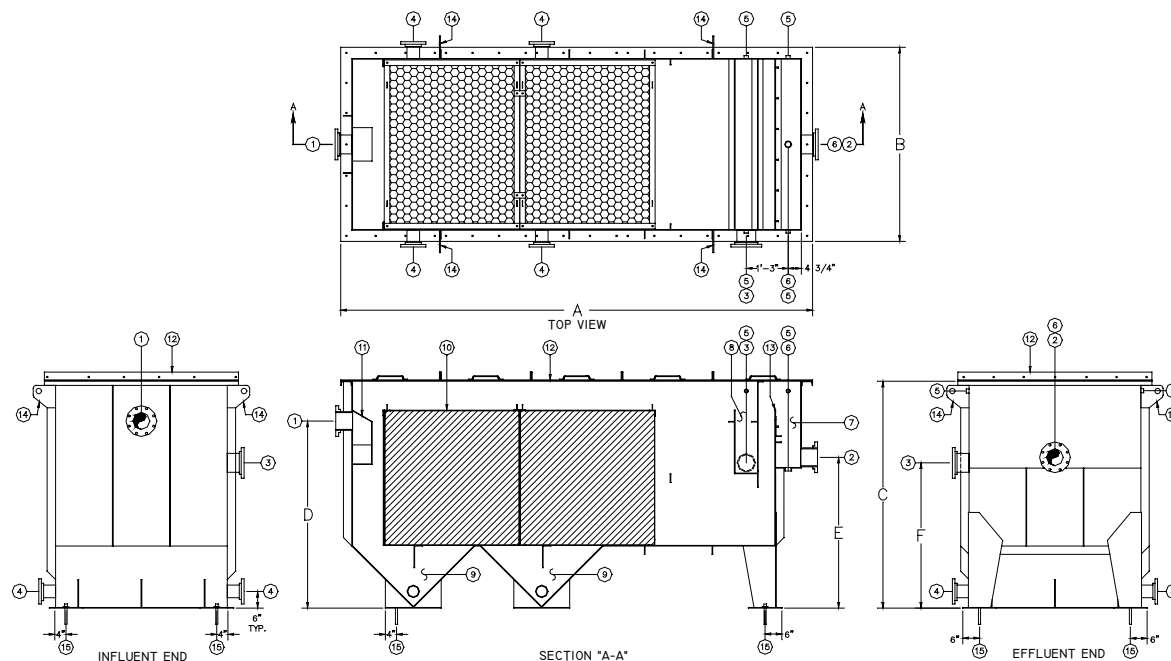

Coalescing Separation Process

When a coalescing media is placed in the wasteflow oils impinge (attach to) the media surface as the oil droplets pass by or run into the media surface. Plastic media typically works best as the petroleum and media materials are attracted to each other.

As the oil droplets adhere to the media they combine (coalesce) into larger droplets and eventually pull away from the media to float on the water surface. Once at the water surface the accumulating oils are skimmed by the oil skimmer and drop into the oil reservoir.

The coalescing process allows the removal of smaller droplets than gravity separation can attain.

Our Flopak coalescing media is designed to provide many changes of flow direction, numerous impact sites and a large surface area. Inclined corrugations in the plate design provide channels for solids settling as well as oil separation.

Construction

Materials of construction are 3/16"-1/4" A36 coated carbon steel. We also offer fiberglass construction of models OS2 through OS16.

Our Flopak coalescing medias are offered in PVC, HPVC, polypropylene, glass-coupled polypropylene, 304 & 316 stainless steel. The media plate spacings offered are 1/2", 3/4", 1" and 1.2".

We also offer high temperature construction for applications where water temperatures exceed our standard 130° F construction.

Model	Length	Width	Height	Inlet	Outlet	Oil Outlet	Sludge Vol. Gal.	Oil Chamber Gal.	Inlet Size	Outlet Size	Sludge Outlet Size	Oil Outlet Size	Empty Weight	Operat. Weight	Flow Rate GPM (Max.)
	A	B	C	D	E	F									
OS-160	14'-1"	5'-10"	6'-9"	5'-7"	4'-7"	4'-4"	125	47	6"	6"	4"	6"	5549	24071	480
OS-192	14'-1"	6'-10"	6'-9"	5'-7"	4'-7"	4'-4"	150	56	8"	8"	4"	6"	6202	28368	576
OS-224	14'-1"	7'-10"	6'-9"	5'-7"	4'-7"	4'-4"	175	66	8"	8"	4"	6"	6904	32713	672
OS-256	14'-1"	8'-10"	6'-9"	5'-7"	4'-7"	4'-4"	200	75	8"	8"	4"	6"	7724	37178	768
OS-288	14'-1"	9'-10"	6'-9"	5'-7"	4'-7"	4'-4"	225	85	8"	8"	4"	6"	8663	41760	864

Item	Qty	Desc	Qty	Desc	Qty	Desc	Qty	Desc	Qty	Desc	Qty	Desc		
1	1	Inlet	4	1	Sludge outlet	7	1	Effluent chamber	10	2	Flopak	13	1	Weir
2	1	Outlet	5	4	Vent	8	1	Oil reservoir	11	1	Inlet Diffuser	14	4	Lift Lug
3	1	Oil outlet	6	1	Drain	9	2	v-hopper	12	5	Cover	15	4	Anchor

Dimensions, design and capacities are not for construction and are subject to change without notice.

Model
OS

OS

Steel Oil Water Separators

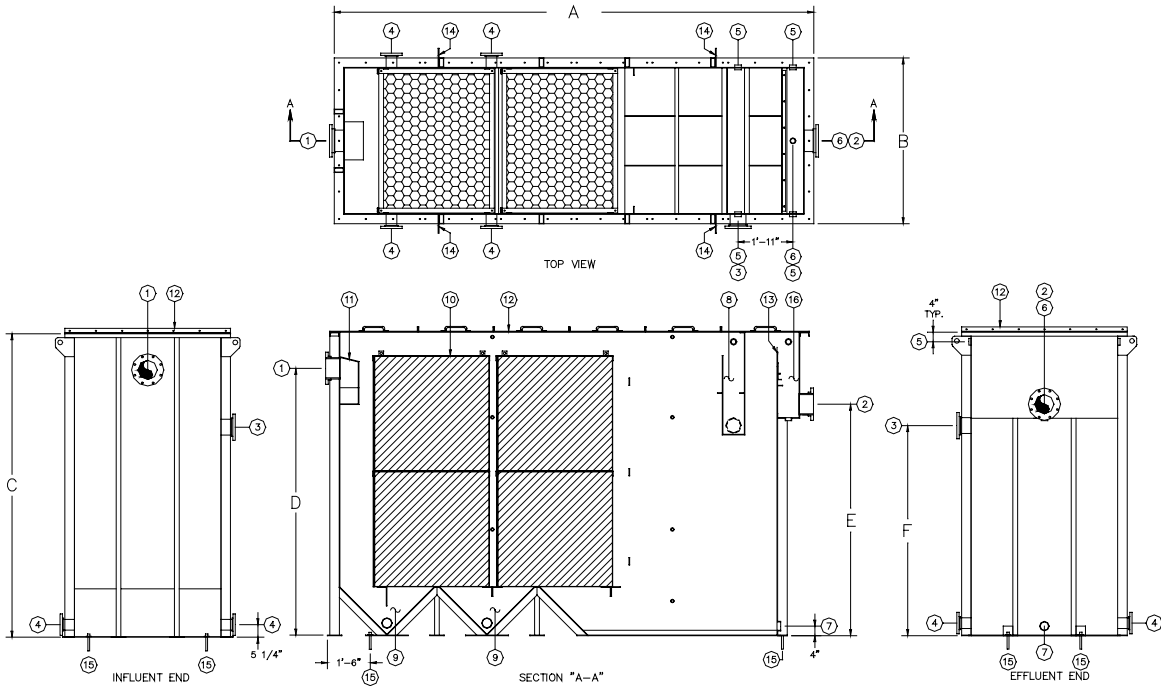

Flopak coalescing media is provided in our separators and provides high performance results in a compact design. Our media facilitates oil/fuel and solids removal and can be provided to update or convert your existing tank or separator to take advantage of our technology.

The standard Flopak is PVC with other materials of construction being offered to tailor your OS separator to your project needs. Media construction offered: HPVC, polypropylene, glass-impregnated polypropylene, 304 or 316 SS.

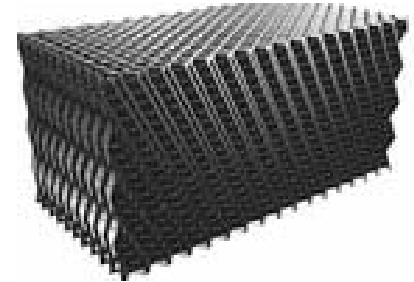

Retpak secondary coalescing media

is offered to further increase performance by removing the smaller oil droplets from the wastestream.



Model	Length	Width	Height	Inlet	Outlet	Oil Outlet	Sludge Vol. Gal.	Oil Chamber Gal.	Inlet Size	Outlet Size	Sludge Outlet Size	Oil Outlet Size	Empty Weight	Operat. Weight	Flow Rate GPM (Max.)
	A	B	C	D	E	F									
OS-320	16'-9"	5'-10"	10'-11"	9'-8"	8'-5"	7'-8"	210	75	8"	6"	4"	6"	11138	56613	960
OS-384	16'-9"	6'-10"	10'-11"	9'-8"	8'-5"	7'-8"	250	95	8"	6"	4"	6"	11996	65845	1152
OS-448	16'-9"	7'-10"	10'-11"	9'-8"	8'-5"	7'-8"	290	110	8"	6"	4"	6"	13074	75775	1344
OS-512	16'-9"	8'-10"	10'-11"	9'-8"	8'-5"	7'-8"	330	125	8"	6"	4"	6"	14135	85688	1536
OS-576	16'-9"	9'-10"	10'-11"	9'-8"	8'-5"	7'-8"	370	140	8"	6"	4"	6"	15153	95538	1728

Item	Qty	Desc	Qty	Desc	Qty	Desc	Qty	Desc	Qty	Desc	Qty	Desc		
1	1	Inlet	4	1	Sludge outlet Vent	7	1	Effluent chamber	10	2	Flopak	13	1	Weir
2	1	Outlet	5	4	Oil reservoir	8	1	Oil v-hopper	11	1	Inlet Diffuser	14	4	Lift Lug
3	1	Oil outlet	6	1	Drain	9	2		12	5	Cover	15	4	Anchor

Dimensions, design and capacities are not for construction and are subject to change without notice.

950 N. Rand Rd., Ste 120 Wauconda, IL 60084 USA 847-487-9166 fax: 847-487-9218 panam@panamenv.com



Model
OS

OS

Steel Oil Water Separators

Custom configurations are offered to tailor a system to your needs and project requirements. Entirely skid mounted systems can be provided.

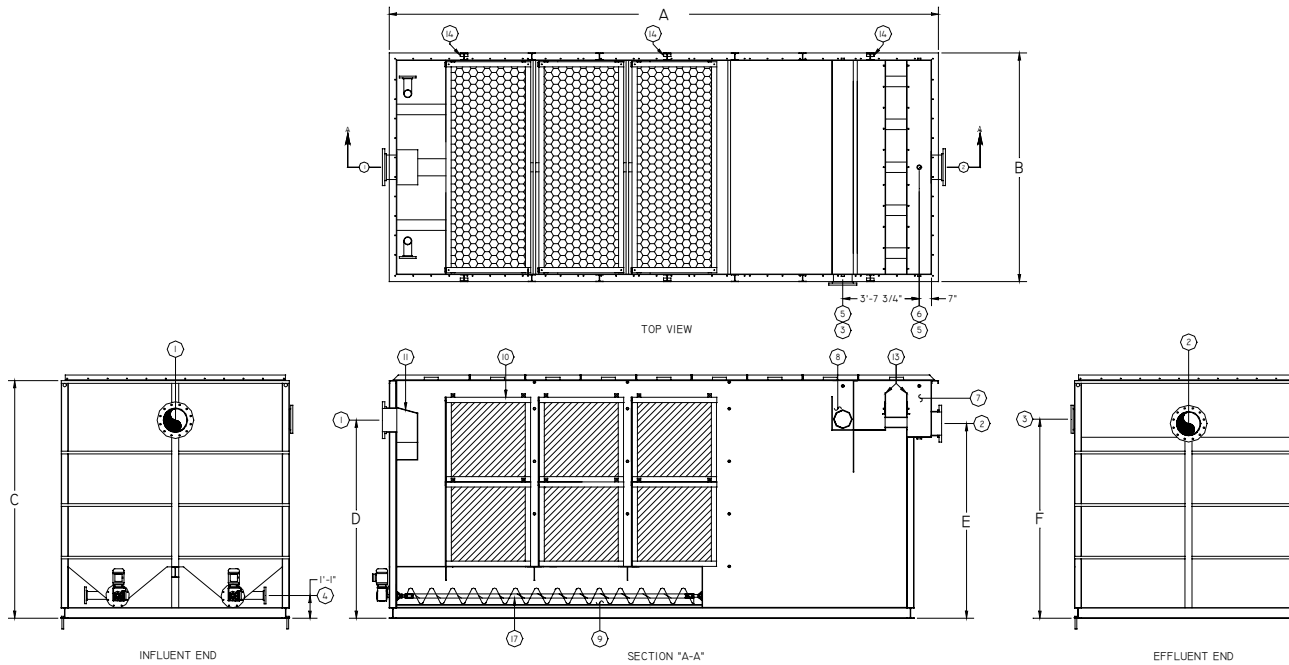

Smaller Flow Rates can be treated with our OSF fiberglass oil water separators for a compact, small footprint, high performance light weight design. Flow rates from 1-50 GPM can be treated with one of our 5 OSF separator sizes.



Model	Length	Width	Height	Inlet	Outlet	Oil Outlet	Sludge Vol. Gal.	Oil Chamber Gal.	Inlet Size	Outlet Size	Sludge Outlet Size	Oil Outlet Size	Empty Weight	Operat. Weight	Flow Rate GPM (Max.)
	A	B	C	D	E	F									
OS-640	21'-7"	8'-10"	11'-3"	9'-5"	9'-3"	9'-5"	290	112	12"	12"	4"	10"	23000	115000	1600
OS-720	22'-7"	9'-10"	11'-3"	9'-5"	9'-3"	9'-5"	290	125	12"	12"	4"	10"	25000	154000	1800
OS-800	24'-2"	10'-10"	11'-3"	9'-5"	9'-3"	9'-5"	316	140	14"	14"	4"	10"	27500	160800	2000
OS-960	26'-2"	10'-10"	11'-3"	9'-5"	9'-3"	9'-5"	368	140	14"	14"	4"	10"	29350	167000	2400
OS-1120	32'-0"	10'-10"	11'-7"	9'-5"	9'-3"	9'-5"	395	200	20"	20"	4"	12"	34700	224000	2800
OS-1280	37'-6"	10'-10"	11'-7"	9'-5"	9'-3"	9'-5"	420	200	24"	24"	4"	12"	37200	263000	3200
OS-1386	36'-0"	11'-10"	12'-4"	10'-5"	10'-3"	9'-5"	470	225	24"	24"	4"	12"	38800	295000	3465
OS-1760	37'-6"	11'-10"	13'-4"	11'-5"	11'-3"	10'-0"	520	250	2/20"	2/20"	4"	14"	41400	336000	4400
OS-1936	42'-0"	11'-10"	14'-4"	12'-5"	12'-3"	10'-0"	700	275	2/20"	2/20"	4"	14"	45650	410000	4840
OS-2112	43'-6"	11'-10"	15'-4"	13'-5"	13'-3"	11'-0"	780	275	2/24"	2/24"	4"	14"	50900	450000	5280

Item	Qty	Desc	Qty	Desc	Qty	Desc	Qty	Desc	Qty	Desc	Qty	Desc		
1	1	Inlet	4	1	Sludge outlet	7	1	Effluent chamber	10	2	Flopak	13	2	Weir
2	1	Outlet	5	4	Vent	8	1	Oil reservoir	11	1	Inlet Diffuser	14	6	Lift Lug
3	1	Oil outlet	6	1	Drain	9	2	v-hopper	12	10	Cover	17	2	Auger

Dimensions, design and capacities are not for construction and are subject to change without notice.

950 N. Rand Rd., Ste 120 Wauconda, IL 60084 USA 847-487-9166 fax: 847-487-9218 panam@panamenv.com



www.panamenv.com

OS Steel Oil Water Separators Engineering Specification

Model OS-2 thru OS2112

Performance

The Pan America Environmental OS Series Oil/Water Separators are designed to produce an effluent concentration of 10 mg/l or less of oil droplets 30 micron and larger of non-emulsified, free and dispersed oils. By virtue of our Flopak coalescing media and tank design, readily settleable solids are also removed.

Section 1.0 Separator Design

1.01 Design

The oil/water separator will be designed and fabricated per the following specifications. Rectangular tankage with features as described designed per API #421 Design & Operation of Oil/Water Separators Manual and Stokes Law. The design will incorporate flexible flow rating capability based on application parameters.

1.02 Influent Chamber

Influent flow enters the clog proof influent diffuser and is immediately spread out across the depth and width of the chamber. Any readily settleable solids drop to the bottom of the V-shaped solids accumulation chamber located directly under the Flopak coalescing media pack.

1.03 Oil/Water Separation Chamber

The separation chamber is to be packed with Flopak cross-fluted coalescing media. The media pack will be designed to create a quiescent zone, a laminar flow pattern to facilitate the impingement of oil on the media, and will provide numerous impact sites and changes of flow direction. The media shall have a 60-degree cross-flute angle.

1.04 Solids Accumulation Chamber

The separator shall have a V-shaped solids accumulation chamber located under the coalescing media. This chamber will provide temporary solids storage. The chamber walls are to be pitched at 45 degrees to assure simple and thorough solids removal. Dual outlet ports will be provided for sludge removal. Hopper design shall allow an optional sludge auger system to be accommodated at the factory.

1.05 Clean Water Effluent Chamber

The cleansed water will flow under the oil retention baffle, over the water weir and into the effluent chamber. This chamber is to have the capability to be expanded at the

factory by modifying the standard integral chamber so a greater volume of water is available for pump suction directly from the OS tank.

1.06 Oil Reservoir

A fixed weir oil skimmer with an integral oil reservoir is to be provided for the temporary storage of separated oils. This chamber is located at the effluent end of the separator. The reservoir will have fittings for pump suction, high/low level switch accommodation and vent. This chamber is to have the capability to be expanded at the factory by modifying the standard integral chamber so a greater volume of oil can be stored and pumped directly from the OS tank to desired point of discharge.

1.07 Separator Cover

The separator is to have a multi-section cover that provides complete closure of the tank. The separator cover will be mounted to the tank via zinc plate hardware and vapor sealed with an industrial grade closed cell, compressible polyethylene gasket.

1.08 Skid & Lifting Lugs

The OS tank shall be provided with an integral, skid base with anchor bolt holes (hardware by others). Lifting lugs shall be provided.

1.09 Fittings

All fittings are to be FNPT coupling up to 3". Fittings larger to be 150# FF ANSI B16.5 flange.

1.10 Sludge Auger System (standard on OS640 & larger)

The solids hopper is provided with a dual, rotating, screw type sludge auger system. The auger consists of stainless steel shafts with coated steel screw auger driven by a slow speed gear motor drive assembly. The auger extends the full length of the solids hoppers and conveys solids to the sludge outlet. A Nema 4 on/off control box is provided, power required: 230 or 460V/3ph/60Hz.

Section 2.0 Materials of Construction

2.01 Steel Construction

Tank shell, baffles, cover and external structural members shall be constructed of A-36 carbon steel. Welded joints are continuous double welded and dye penetrant tested.

2.02 Surface Preparation

Interior surfaces shall be prepared to an SSPC-SP10 near white metal blast. Exterior surfaces shall be prepared to an SSPC-SP6 commercial blast.

2.03 Coatings

Interior coating shall be a self-priming, coal tar epoxy (14-16 mils DFT). Exterior coating shall be primer coat followed by industrial polyurethane enamel coat (6 mils DFT). Color is Green.

2.04 Piping

Internal piping shall be ASTM, A-53 black steel.

2.05 Coalescing Media

Flopak, cross-fluted, oleophilic, PVC coalescing media shall be provided as manufactured by Pan America Environmental. The media shall be packed in 304 stainless steel frame(s) with lifting lugs and removable cover (media frame provided with OS-24 & larger).

2.06 Cover Gasketing

Closed cell, industrial grade polyethylene constructed vapor sealed cover gasketing shall be provided. No neoprene shall be permitted.

2.07 Manufacturer

The manufacturer of preference shall be:
Pan America Environmental, Inc.

2.08 Warranty

Pan America Environmental warrants its products to be free of defect in materials and workmanship for a period of one year from the date of shipment.



950 N. Rand Rd., Ste 120
Wauconda, IL 60084 USA
847-487-9166 847-487-9218 fax

panam@panamenv.com

www.panamenv.com

Oil Water Separator Options Descriptions

Influent Feed System Air operated, diaphragm pump with air controls or progressive cavity pump, sump level switches & Nema 4 control panel, base mounted, 115/230/460V power offered. Electric diaphragm pumps available.

Effluent Pumpout Centrifugal pump with level switches & Nema 4 control panel, base mounted, 115/230/460V power offered. OS Effluent chamber must be expanded to accommodate pumpout or provision of an external pumpout tank.

Sludge Pumpout System Air operated, diaphragm pump with air controls & Nema 4 control panel, auto on/off timer, base mounted, 115V/1ph/60Hz power req'd. Progressive cavity pump system also available. 1 - 100 GPM.

Oil Pumpout System Air operated, diaphragm pump with air controls, level switches & Nema 4 control panel, base mounted, 115V/1ph/60Hz power req'd. Electric gear or progressive pump systems available. 1 - 100 GPM (larger if required)

Sludge Auger OS separator V-hopper(s) can be provided with a sludge auger. System consists of stainless steel shafts with coated steel screw auger(s) driven by a slow speed gear motor drive assembly. The auger extends the full length of the solids hopper(s) and conveys solids to the sludge outlet. A Nema 4 on/off control box is provided, power required: 230 or 460V/3ph/60Hz.

Freeze Protection Immersion heaters mounted through tank wall. Each heater has an independent thermocouple well, 0-100 deg. F thermostat and Nema 1 (or optional Nema 4) housing. 230/460V/3ph/60Hz power req'd.

Retpak Secondary Coalescer High surface area, reticulated, secondary coalescing media for polishing flow after standard Flopak media.

Oil Sight Glass Two automatic, brass valves with tempered sight glass and protection rods mounted in oil reservoir. If glass is broken check ball stops outflow from reservoir.

External Sight / Level Glass An externally mounted clear PVC sight tube is provided with multi-point

level switch for indication or pump control of oil or water. Switch is removable for cleaning and inspection.

Elevation Stand Epoxy coated steel stand or legs to elevate tank to desired level. Standard deck height is 30". Full platforms & walkways with ladders or stairways can be designed where required or desired.

High Temperature Design Flopak coalescing media and any piping is constructed of a combination of CPVC &/or polypropylene (or other materials) for temperature resistance up to 200° F.

Alternate Media Construction Standard Flopak media is PVC. HPVC, polypropylene, glass-coupled polypropylene and 304/316 stainless media is available. Contact PAE to determine proper media type for your application. Media plate spacing is available in 1/2", 3/4" & 1.2".

External Storage/Feed Tanks A wide variety of tank volumes can be supplied for your water, product and sludge holding needs. Flat bottom and cone bottom designs constructed in polyethylene, fiberglass, steel & stainless steel can be provided.

Effluent Filter Systems Solids filter systems can be provided to remove filterable solids from the separator effluent. Contact Pan America to determine proper filtration needs for your application.

AQAM Filter Systems AQAM (Alkyl Quaternary Ammonium Montmorillonite) filter systems can be provided to remove trace hydrocarbons, sheens, DNAPLs, slightly soluble chlorinated hydrocarbons and high molecular weight organics from the separator effluent. Contact Pan America to determine proper filtration needs for your application. Can be used to protect and increase GAC lifespan.

Carbon Filtration Systems (GAC) GAC carbon filters can be provided to remove contaminants after the separator. Contact Pan America to determine proper system needs for your application.

Emulsion Cracking Systems Emulsion cracking systems can be provided to remove oil-in-water emulsions prior to the separator. Contact Pan America to determine proper system needs for your application.

pH Adjustment Systems pH adjustment systems can be provided to maintain pH levels prior to or after the separator. Contact Pan America to determine proper system needs for your application.

System Containerization OS separators with any options can be installed in a 20 or 40' shipping container(s) to simplify system provision and field implementation. System would include the complete mounting, piping and wiring of the system in one or more container as required by the project.

Trailer Mounting OS separators can be mounted on a trailer for system mobilization. Trailer design generally includes corner leveling jacks, bubble levels, walkway, toolbox, electric or hydraulic brakes, piping and wiring of options.

Field Skid Mounting OS separator system can be mounted to a mobile skid with leveling for quick field mobilization.

Skid Mounted System OS separators can be combined with our other treatment equipment and options into a fully integrated, custom designed system completely mounted, plumbed and wired to a system skid. To simplify your need to do the wiring and plumbing on site, reducing your time frames and on site costs, we design around your requirements.

Vent Scrubber Separator vapors can be extracted and scrubbed prior to discharge to atmosphere to remove VOC content.

Level Sensors Level sensors can be provided to detect water and oil/fuels. One or more sensor points can be provided to perform various functions such as high level, low level, pump on/off based on liquid levels and level detection for DCS controls or other functions based on your needs.

Class 1 Div 1 & 2 Systems can be designed for use in a class 1 div 1 or 2 environment. Controls, components and wiring are changed to meet the needs of these environments. Intrinsically safe relays are also used for level sensors.

Oil Monitor An oil detection system can be provided to monitor effluent oil content and provide various actions based on the oil alarm setpoint. Actions might include: audible/visual alarm, redirection of influent or effluent via actuated valve, shutdown of influent pump or your custom action.



www.panamenv.com

Oil Water Separation Theory

Coalescing Oil Water Separators: Coalescing Oil Water Separators are passive, physical separation systems designed for removal of oils, fuels, hydraulic fluids, LNAPL and DNAPL products from water. Pan America Environmental's designed performance can be described by a combination of Stoke's Law and current coalescing plate theory, wherein, the oil droplet rise rate and other parameters dictate the surface area required for gravity & coalescent separation.

Separation Process: The water/oil mixture enters the separator and is spread out horizontally, distributed through an energy and turbulence-diffusing device. The mixture enters the Flopak media where laminar and sinusoidal flow is established and the oils impinge on the media surface. As oils accumulate they coalesce into larger droplets, rising upward through the pack corrugations until they reach the top of the pack, where they detach and rise to the water's surface. At the same time solids encounter the media and slide down the corrugations, falling into the v-hopper under the Flopak media.

Stoke's Law: This equation relates the terminal settling or rise velocity of a smooth, rigid sphere in a viscous fluid of known density and viscosity to the diameter of the sphere when subjected to a known force field (gravity). The equation is:

$$V = (2gr^2)(d1-d2)/9\mu$$

where

V = velocity of rise (cm sec⁻¹),
 g = acceleration of gravity (cm sec⁻²),
 r = "equivalent" radius of particle (cm),
 d1 = density of particle (g cm⁻³),
 d2 = density of medium (g cm⁻³), and
 μ = viscosity of medium (dyne sec cm⁻²).

Coalescence: Gravity separation utilizes the difference in specific gravity between the oil and water. Oil separates from a fluid at a rate explained by Stoke's Law. The formula predicts how fast an oil droplet will rise or settle through water based on the density and size of the oil droplet size and the distance the object must travel. Our separators are built to exploit both variables of Stokes Law.

With the use of our Flopak media oil only need rise a short distance before encountering the oleophilic, coalescing media plates inside the separation chamber as opposed to rising a great distance in gravity separation. Upon impinging on the plates the oils coalesce (gather) into larger droplets until the droplet buoyancy is sufficient to pull

away from the media and rise to the water's surface. The design will meet particular design criteria as indicated below:

- The hydraulic distribution of the influent flow must assure full usage of the cross-sectional area of the media to fully utilize the plate pack's surface area.
- Flow control and direction must be determined to prevent hydraulic short circuiting around, under or over the media pack.
- A laminar flow condition must be maintained (Reynolds "Re" number less than 500) in order to assist droplets to rise. Per the American Petroleum Institute's (API) Publication 421 of February 1990.
- Horizontal flow through velocities in the separator must not exceed 3 feet per minute or 15 times the rate of rise of the droplets which ever is smaller.
- The media containment chamber design, plate design/angle and spacing sufficient to facilitate removal of accumulating solids. Plates are to be smooth surfaced and angled at 60 deg.

Flopak Coalescing Media Design

Pan America's Flopak coalescing media provides a laminar flow path that creates a quiescent zone to facilitate the impact with and attachment of oils to the media surface by reducing wastestream turbulence and velocity. This control of the wastestream creates a more ideal environment for oil removal. By virtue of our Flopak media design, solids will also collide with the media and settle to the separator bottom to some degree. Due to oil typically being lighter than water, they (oil) will rise up the coalescing plate. As the oil droplets rise up the plate they will coalesce or come together with other droplets, creating progressively larger droplets. Once the droplet size is sufficient or the droplet reaches the top of the media plate the droplet pulls away from the plate and rises to the water surface. To some degree, the solids replicate this process in reverse (settling).

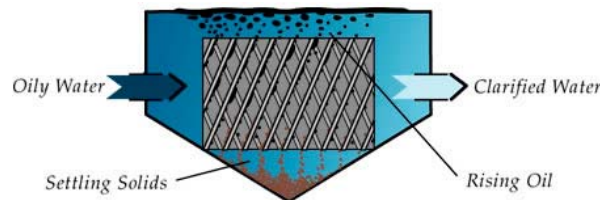

Gravity Separation vs Coalescing Plates

Two types of oil water separator exist today in varying types of design, but all are dependent on these two types of design.

The first and oldest type is gravity or conventional separation, simple separation via gravity (density differential between two immiscible liquids leads to one of them rising above the other). This design, when designed properly (or even improperly) provides a certain tank length, width and depth that provides a wide, quiet spot in the pipeline to give oils time to rise. This design (also known as an API separator) generally provides a discharge oil concentration of 100 ppm based on a 150 micron droplet size. The API type design relies on a large water volume. This correlates to a tank size that can be 5 times the size of an equally sized coalescing separator.

The coalescing design is known by many names ie. parallel plate, corrugated plate, slant rib coalescer so on and so forth. However, the concept, operation and design are generally the same. The coalescing concept is based on having a large surface area in contact with the wastestream (coalescing plates). The more surface area provided, the more enhanced the separation process will typically be. By using the coalescing media, the size of the tank is reduced and a higher performance is attained than by gravity separation. Pan America's Flopak coalescing design provides a discharge oil concentration of 10 ppm or less with an oil droplet size of 30 or as small as a 20 micron oil droplet.

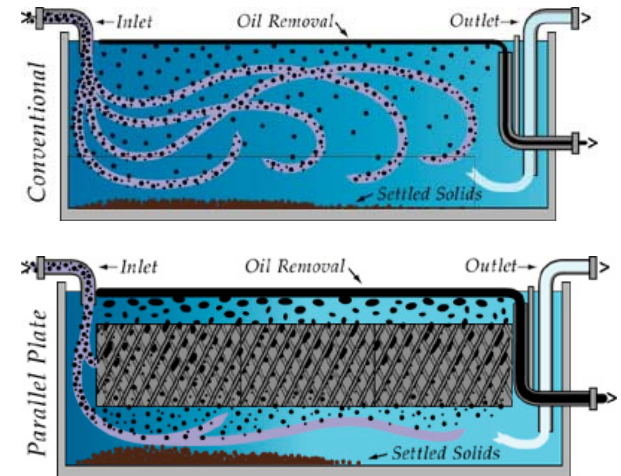

950 N. Rand Rd., Ste 120
 Wauconda, IL 60084 USA
 847-487-9167 847-487-9218 fax
panam@panamenv.com

www.panamenv.com

Bulletin: os04.pdf